

ENVIROWASH P1 PORTABLE UNIT

Pioneering Environmentally Safe Washouts



The EnviroWash system operates with a closed loop recycling process, which means that all water used in the system is recycled, treated, and reused. So the water you start with is the water you end with. The impact that this can have on our water supply is truly astounding considering that millions of gallons of water are used each year for concrete washout, and possibly even more rainwater is contaminated by overflow and leakage of washout wastewater.

THE ENVIROWASH SYSTEM – WHAT IT IS

The EnviroWash, developed by Waste Crete Systems, is the only concrete washout solution that prevents nearly 100% of rainwater and groundwater contamination throughout the building process with patent pending closed-loop concrete wastewater recycling, treatment and handling technology.

CLEAR BENEFITS

- EPA Compliance
- Safety
- Cost-effective
- Water conservation
- Easy-operation
- Designed to meet your needs

HOW IT WORKS

The EnviroWash P1 (Portable Unit) is composed of five core components: Hinged and locked hoppers, a pumping system comprised of sump and pressure pumps, central walkway, forced weir tank system, and control box. In a nutshell, the closed-loop all-in-one system captures concrete wastewater in hinged hoppers; the pumping system then collects wastewater from under the hoppers and deposits it into the forced weir tank system for separation and filtration. The recycled water is then pumped into the hoppers for reuse. This process maintains a viable source of recycled water that can be used for an indefinite period of time.

THE ENVIROWASH CONCRETE WASTEWATER HANDLING SYSTEM

Pioneering Environmentally Safe Washouts



WHEN TO USE IT

The EnviroWash P1 Portable is an all-in-one unit designed for use at smaller building/construction sites and can handle approximately 15-30 trucks and the washout from one pump. It is a semi-permanent one-hopper unit with an attached forced weir tank system. No ramp is required and the unit is two-truck accessible.

WHAT ABOUT SERVICE & MAINTENANCE

Parent company, Waste Crete Systems, LLC, provides complete training and support for the EnviroWash team of service providers, as well as, the entire EnviroWash family of washout products. Our licensed service providers will fully service and support every EnviroWash unit including water treatment or removal if needed.

PATENT PENDING

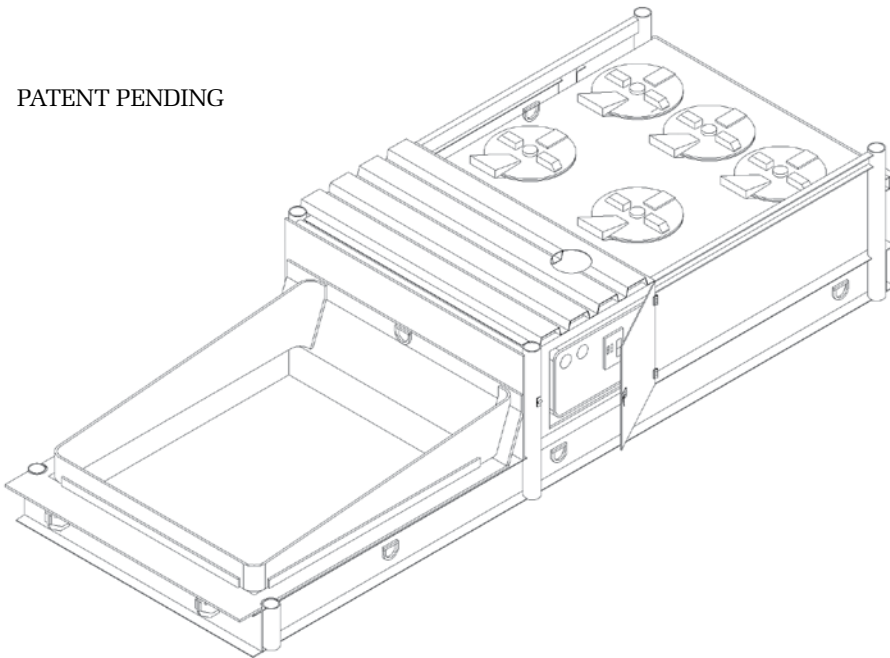

ENVIROWASH P1 SPECS & MEASUREMENTS

The size of the P1 is 15'-6" long by 6'-6" wide and 34" tall. The concrete hopper is a 1-yard hopper. The P1 unit has a generator for power, or may be plugged in with an extension cord. It weighs approximately 7,000 lbs. empty and 12,000 lbs. full.

TARGETED POLLUTANTS

Suspended Solids	Cement, fly ash particles, sand, dirt, and etc.
Caustic Wastewater	Water with a PH level of more than 11 units

Waste Crete Systems, LLC
Corporate Headquarters
7015 San Antonio, Suite B
Houston, Texas 77040
tel: 713.937.9699
www.envirowashout.com

